

Instruction Manual

2312

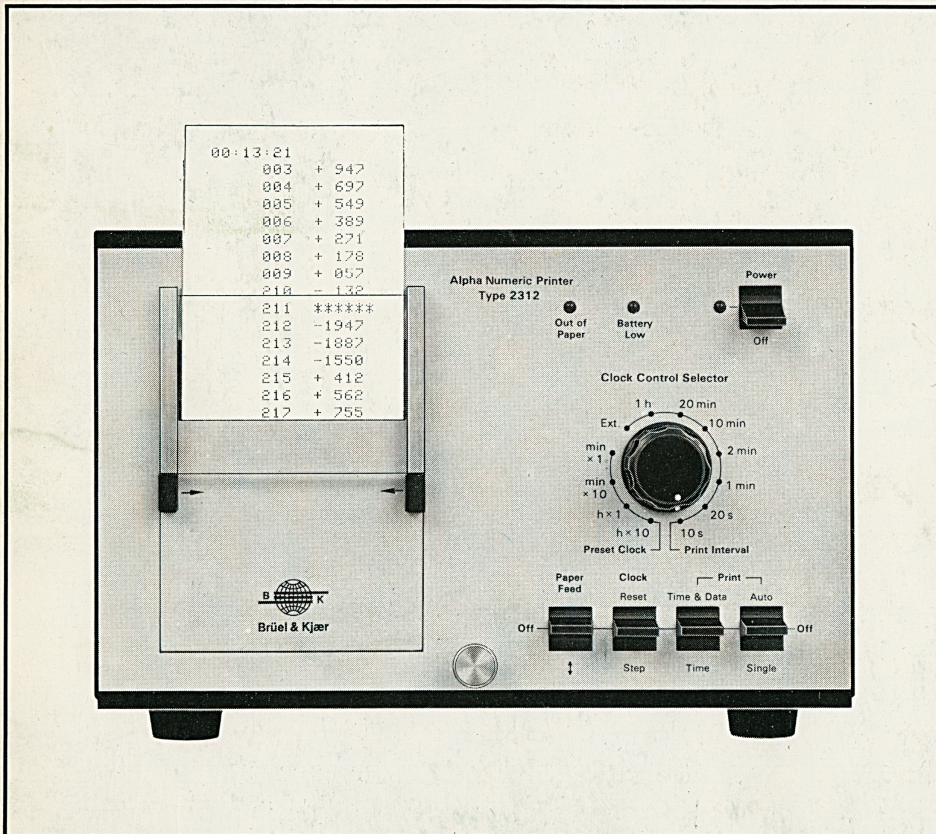

Alphanumeric Printer Type 2312



A low-power battery-operated alphanumeric printer which is fully compatible with the proposed IEC Interface Bus Standard using a selectable "Addressable" or a "Listen Always" mode. A modified IEC system is also selectable for low-power use with other compatible B & K instruments. The thermal-printing system using heat-sensitive paper enables the printer to operate virtually silently, and gives a battery life of up to 6 weeks, using a special "Low-Power Operation" setting. In addition to the data print-out, the day, hour, and minute can also be printed out automatically, timed by a crystal-controlled clock. The print-out may be left or right justified, and the first data line appears at the top of the paper. Print-out intervals can be controlled by the internal clock or externally, and the printer can be operated from the mains if required by using a plug-in power supply.

**ALPHANUMERIC PRINTER
TYPE 2312**

May 1977

CONTENTS

1. INTRODUCTION AND SPECIFICATIONS (PRODUCT DATA)	1
2. CONTROLS	5
2.1. FRONT PANEL	5
2.2. REAR PANEL	7
3. OPERATION	10
3.1. MOUNTING	10
3.2. POWER SUPPLY	10
Plug-in Power Pack	11
Plug-in Power Supply Type 2808	13
Battery Charger ZG 0113	15
3.3. GROUNDING THE 2312	15
3.4. HEAT RESISTORS	16
3.5. PREPARATION FOR USE/MAINTENANCE	17
Printer Head	17
Paper-feed Rubber Roller	17
3.6. PAPER LOADING AND STORAGE	17
Loading the Paper	17
Paper Storage	18
3.7. SETTING THE CLOCK	18
Initial Setting	18
Resetting the Clock	19
Setting the Day	19
3.8. SELECTION OF CABLES	19
3.9. USE OF THE ALPHANUMERIC PRINTER TYPE 2312	20
4. INTERFACING THE 2312 TO OTHER INSTRUMENTS	24
4.1. PRINCIPLE OF THE PROPOSED IEC INTERFACE	24
4.2. THE B & K LOW-POWER INTERFACE	28
4.3. CODES AND FORMATS FOR THE 2312	28
4.4. COMPATIBILITY	28

FEATURES:

- Internal battery power supply
- Battery life up to 5 weeks
- First data line at top of print-out
- Ability to print 16 characters per line on 60 mm wide paper roll
- Printing rate up to 24 characters per second
- 64 different alphanumeric characters from ASCII upper case set
- Switch selection to align data format with left or right hand edge
- Low-consumption thermal-printing system using heat-sensitive paper
- Quiet operation
- Easy paper loading
- Built-in Interface to the proposed IEC Standard Bus, for direct connection with instruments using this system
- Crystal clock for automatic internal control of print-out intervals
- Wide choice of print-out intervals from 10 s to 1 h
- Provision for control by external clock
- Automatic print-out of day, hour, and minute
- Special "Low Power" setting to reduce battery drain for long term applications
- Acceptance of Type 2808 Power Supply, to run on line voltage

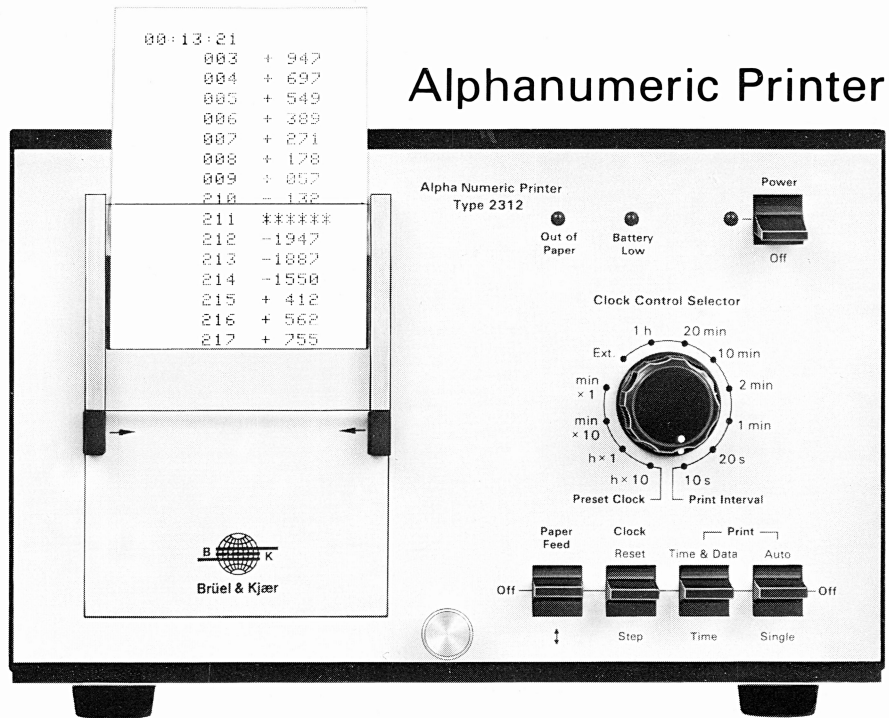

Alphanumeric Printer

USES:

- Direct print-out of statistical data from Type 4426 Noise Level Analyzer
- Direct print-out of point identity and strain level from B & K strain measurement systems consisting of Type 1526, Type 1544, and Types 1545
- Direct print-out of centre frequency and sound level via the built-in (optional) interface of a Digital Frequency Analyzer Type 2131
- Direct print-out of data from any instrument that employs the ASCII Interface Bus system

The Alphanumeric Printer Type 2312 accepts incoming ASCII coded data, resolves them into alphanumeric characters, and prints them out on a paper roll. It functions as an output section to give a hard copy of measurements made with instruments that have an ASCII coded digital output. These include the Noise Level Analyzer Type 4426, the Strain Measurement System made up of Types 1526/1544/1545, and the Digital Frequency Analyzer Type 2131. Battery operation makes the Type 2312 specially suitable for portable applications (with the Type 4426 for example) thereby allowing analyzed data to be printed out immediately in the field. The Type 2312 and Type 4426 can be carried together in the conveniently dimensioned Carrying Case KA 2000, as shown in Fig.1.

Description

The Type 2312 contains a built-in Interface with a choice between three different operation modes:

1) **Addressable** mode, the Interface will operate according to the proposed IEC Interface Bus Standard, with byte-serial transfer of data controlled by three lines operating in the "three wire handshake" mode. The device can be individually addressed by an external controller connected to the Interface Bus. The address is set on a switch array on the rear panel (see Fig.2).

2) **Listen Always** mode, no addressing facility is required as the Printer will print any information transferred on the Bus.

3) **B & K Interface** mode, a simplified version of the IEC Interface Standard specially designed for operation with battery powered equipment.

All internal time sequences are regulated by means of a built-in crystal controlled clock generator that has an overall accuracy better than ± 2 minutes per month, in the full temperature range (-10° to $+50^{\circ}\text{C}$). The clock measures in days, hours, and minutes, which are recorded at the head of each data file to establish the time of origin for identification purposes. By means of a simple "Reset" and "Step" procedure, it is possible to set the clock to the actual time of day before recording a series of measurements. The recording always commences on day "0". Activating the test button "Print Time" provides a print-out of date and time alone.

The internal clock can also be used to start an automatic print-out of data at pre-selected intervals, in steps from 10 seconds to 60 minutes. When it is necessary to use intervals other than those provided by the instrument settings (to obtain intermediate values, or longer intervals) the Type 2312 can be externally controlled by the transmitter, or by an external clock circuit. When under external control, the Printer will still record the day and time as indicated by the inter-

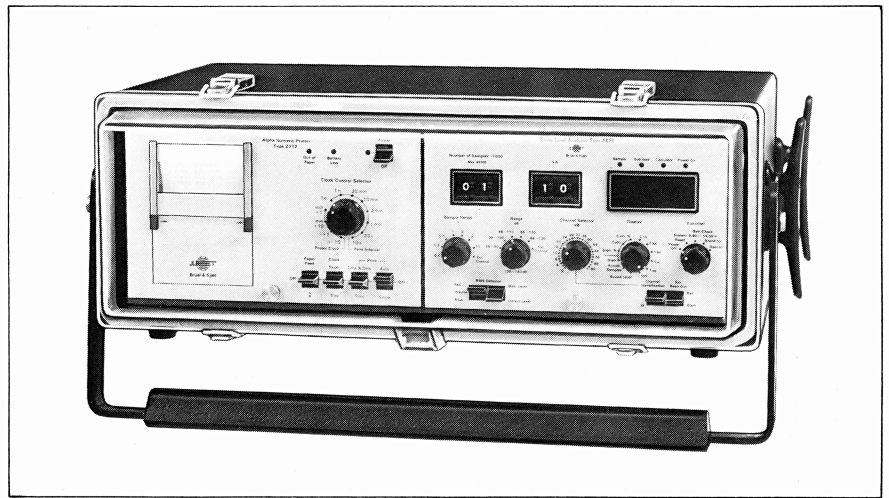

Fig.1. Battery operated Noise Level Analyzer and Alphanumeric Printer installed in a robust carrying case ready for field measurements

nal clock at the head of each data file. A print-out of a single data file can also be started manually.

Because of the paper feed geometry, the first line of data printed will always appear at the top of the print-out. To further simplify reading of the printed data, the Type 2312 is equipped with a change-over switch that aligns the data lines with either the left-hand edge or the right-hand edge of the paper. Left-hand alignment is usual when printing alphanumeric information while right-hand alignment is chosen for pure numerical print-outs, like noise measurements where all dB values can be aligned for easy comparison.

A data **string** consists of one or more characters followed by a Line

Feed, or Carriage Return plus Line Feed, or with the single-line command "End" simultaneous with the last byte. A data **line** is a string with a maximum of 16 characters, while a **file** is composed of one or more lines forming a group.

Data bytes are received and stored before print-out of each line. When a data string contains more than the 16 characters that can be accommodated on the 60 mm paper width, transmission is automatically interrupted and the first 16 characters printed. Then the following characters are transmitted and printed on the next line etc.

A thermal-printing system using heat-sensitive paper is employed that can print 64 different characters in the ASCII upper case series

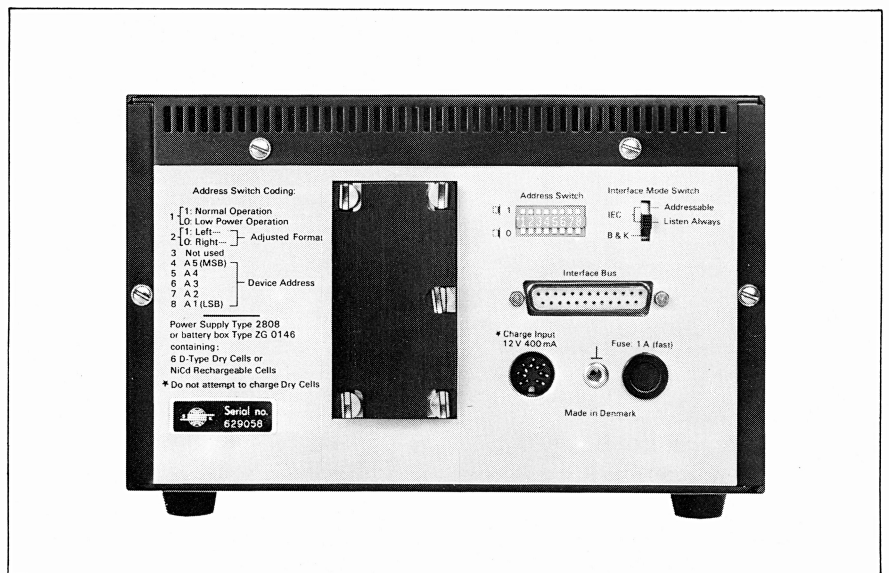

Fig.2. The rear panel of the Type 2312

```

0123456789:;<=>?
@ABCDEFGHIJKLMNO
PQRSTUVWXYZ[\]^_
!"#$%&'()*+,-./

```

Fig.3. The 64 characters available from the ASCII series

in a 5 × 7 dot matrix, see Fig.3. The line speed depends on the number of characters per line. With a full sixteen character line, the printer will print 24 characters per second (1,5 lines per second). With one character per line, line speed will be six lines per second. The paper roll length of 25 m (82 ft) is sufficient for 5000 lines of data. When the paper magazine is empty, the "Out of Paper" lamp blinks and further print-out is inhibited.

It is possible to power the Printer from four alternative sources. In the standard configuration (as supplied), power is derived from a plug-in Battery Box ZG 0146 containing six

1,5V Alkaline "D" cells (IEC type R20). The Battery Box can be replaced by the plug-in Power Supply Type 2808 so that the instrument can be operated from line voltages between 100V and 240V, 50 to 400Hz. Alternatively, the cells in the Battery Box can be replaced by rechargeable nickel-cadmium accumulators, which can be charged by a Type 2808, or by a Battery Charger ZG 0113. The Printer can also be powered by an external 12V DC supply (for example the ZG 0113) via the recharging socket, provided that the instrument contains rechargeable cells.

During print-out the Type 2312 draws an average of 500mA, between print-out the demand falls to 30mA. A selector switch enables a "Low Power" mode to be chosen (only when operating with B & K Interface) so that the standby demand is reduced to 4mA, which gives a lifetime on standby of approximately 5 weeks on fully charged NiCd cells.

When the battery output is not sufficient to drive the Printer, the "Battery Low" lamp blinks, and the print-out is inhibited until the cells have been replaced or recharged.

```

00:13:21
003 + 947
004 + 697
005 + 549
006 + 389
007 + 271
008 + 178
009 + 057
210 - 132
211 *****
212 -1947
213 -1887
214 -1550
215 + 412
216 + 562
217 + 755
218 -1208
219 - 708

```

Fig.5. Typical print-out from strain measurement system (point 211 is indicating "Out of Range")

Fig.4. Strain measurement system consisting of Strain Indicator 1526, Multipoint Selector and Control 1544, Multipoint Selector 1545, and the Alphanumeric Printer in use to determine the strain on a reinforced concrete beam

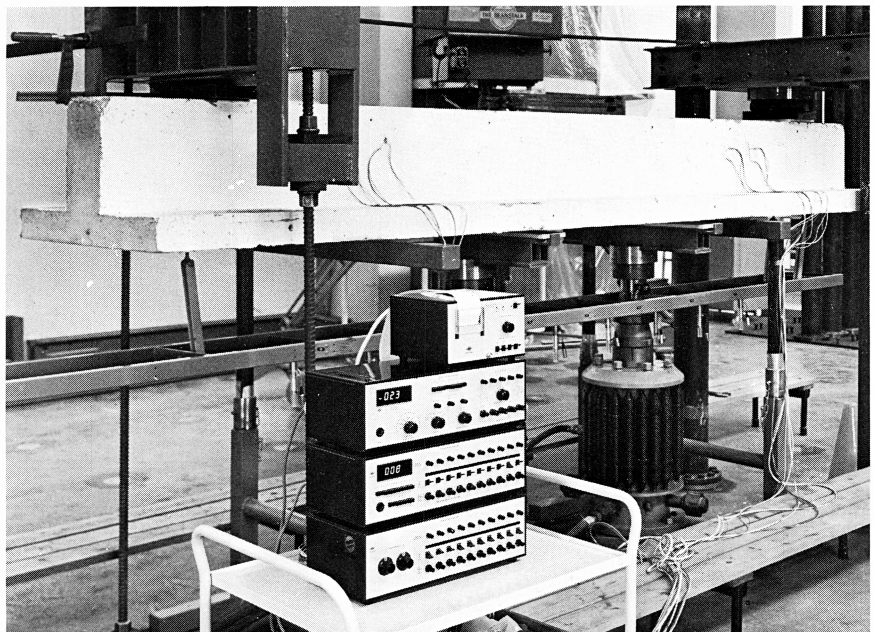

Specifications 2312

Input:

Digital data in 7-bit ASCII-coded form

Interface:

Byte serial in accordance with proposed IEC Interface Bus Standard and, except for the connector, with IEEE 488/1975, and ANSI MC1, 1-1975 Interface Standards

3-way changeover switch for Addressable, Listen Always, or B & K Standard Interface

Printing System:

Thermal-dot printing on heat sensitive paper
64 different alphanumeric characters in the ASCII upper case series

Format:

16 character data line
Left-hand or right-hand data alignment, switch selectable

Printing Rate:

6 to 24 characters per second with
6 to 1,5 lines per second

Paper Roll:

60 mm paper width
25 m (82 ft) roll length sufficient for 5000 lines
55 mm (2,15 in) max. roll diameter to fit magazine

Clock Circuit:

Crystal regulated, measures in days,

hours, and minutes

Provides time print-out at the head of each data file if "End" command is transmitted with last byte

Controls the automatic data print-out at preset intervals of 10 s, 20 s, 1 min., 2 min., 10 min., 20 min., and 60 min.
Accuracy better than ± 2 min./month over full working temperature range

Power Supply: (any of the following)

- 1) $6 \times 1,5$ V batteries, IEC R 20, "D" cells at temperatures above 0°C
- 2) $6 \times 1,2$ V NiCd rechargeable cells
- 3) Line voltages between 100 V and 240 V, 50 to 400 Hz with plug-in Power Supply Type 2808
- 4) External 12 V DC supply, from Type 2808 or ZG 0113 via charging socket **only** when rechargeable cells are in the instrument

Current Consumption:

1,4 A maximum for impulses up to 10 ms during print-out
500 mA average during print-out (< 4 W)
 < 30 mA during standby with normal operation
 < 4 mA during standby with "Low Power" operation

Battery Life: (Rechargeable cells, 4 Ah)

5 weeks of standby with "Low Power" operation at 20°C (68°F)
8 hours with continuous print-out of 16 characters/line (40000 lines = 8 rolls)

Battery life at standby is reduced 85 s per full line printed

Using Alkaline batteries will increase the operation time by a factor of 2 to 3

Operating Temperature:

-10 to $+50^{\circ}\text{C}$ (14 to 122°F)
 0 to $+50^{\circ}\text{C}$ (32 to 122°F) Zinc-carbon or alkaline batteries

Dimensions:

Height: 132,6 mm (5,2 in)

Width: 209,5 mm (8,3 in)

Depth: 200 mm (7,9 in)
(6/12 of 19" rack module)

Weight: (with standard batteries)

3,3 kg (7,25 lb)

Accessories Included:

6 Alkaline dry cells QB 0020
1 Battery Box ZG 0146
10 Rolls of heat sensitive paper ($2 \times$ QP 0006)
Multipin Connector JP 2500
7-pin Din Plug JP 0703

Accessories Available:

Rechargeable NiCd-cells QB 0008
Battery Charger ZG 0113
Power Supply Type 2808
Cable AQ 0035 for recharging from Type 2808
Charging Adaptor AQ 0157
Mahogany Case KA 0037
Packages of 5 rolls of paper QP 0006
25 lead interface cable (0,6 m) AO 0144
25 lead interface cable (1,5 m) AO 0129
25 lead flat cable (0,4 m) AQ 0138

2. CONTROLS

2.1. FRONT PANEL

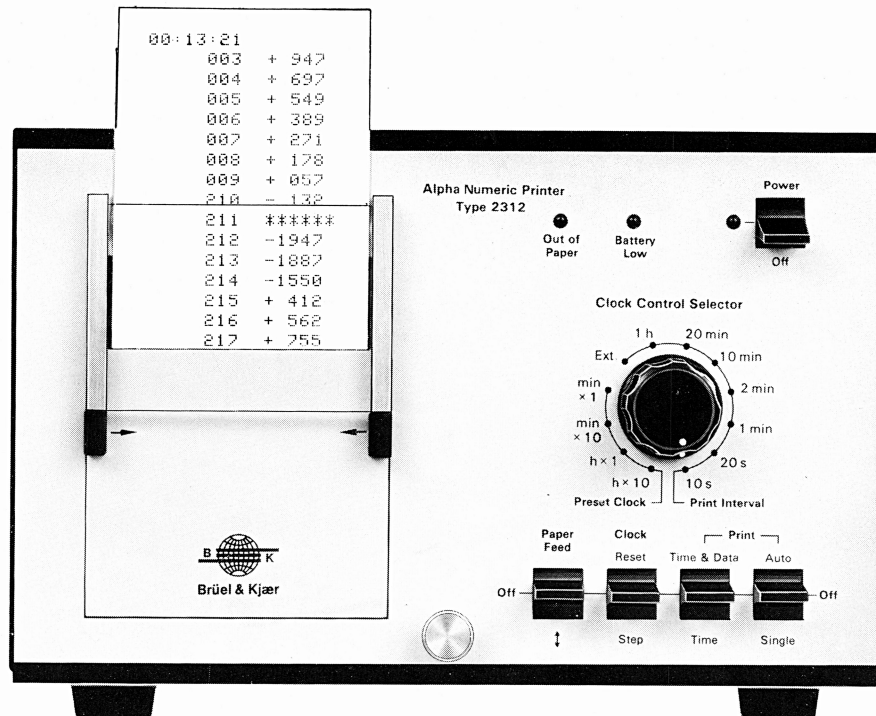

Fig.2.1. Front Panel of 2312

- POWER ON:** Two-position paddle switch for turning power on and off. When in the up position ("On"), the red lamp just to the left of the switch will light or flash.
- POWER ON INDICATOR:** This red lamp will be lit continuously when the instrument is switched on in its "Normal Operation" mode, and it will flash in the "Low-Power Operation" mode.
- BATTERY LOW INDICATOR:** This red lamp will flash when the batteries need to be replaced or recharged, as appropriate. See section 3.2. Data printout is inhibited until the batteries are replaced or recharged.
- OUT OF PAPER INDICATOR:** This red lamp will flash when the paper has run out. Data print-out is inhibited until a new roll of paper is inserted.
- CLOCK CONTROL SELECTOR:** This 12-position rotary switch has two functions as follows:
- "Preset Clock":** The four positions marked "h x 10" (hours x 10), "h

× 1", "min × 10" and "min × 1" are used in conjunction with the CLOCK paddle switch to select the individual digits in the internal 24-hour clock, when it is being set to the actual time of day. See section 3.7.

"Print Interval": The time between print-outs is selected by turning the CLOCK CONTROL SELECTOR to any one of the eight positions marked "10 s", "20 s", "1 min", "2 min", "10 min", "20 min", "1 h" or "Ext.". In the "Ext." position, the print interval is controlled by the instrument supplying the data to be printed.

PAPER FEED:

A three-position self-centring paddle switch for feeding out the paper. In the central "Off" position, the paper is only fed out during print-out. If either the upper or lower position is selected, the paper will move forward until the switch is released.

CLOCK:

A three-position self-centring paddle switch for use in conjunction with the CLOCK CONTROL SELECTOR in one of its "Preset Clock" positions to select the individual digits in the internal 24-hour clock, when it is being set to the actual time of day.

It has the following functions:

"Reset": In this up position, the internal clock will be reset to "00:00:00" only if the CLOCK CONTROL SELECTOR is in one of the "Preset Clock" positions.

"Step": Each time the switch is depressed to this down position, the clock digit selected by the "Preset Clock" position of the CLOCK CONTROL SELECTOR will be advanced by one count.

The centre position of the switch (unmarked) is off.

See section 3.7.

PRINT:

Two three-position paddle switches for controlling the print-out. Both have locking upper and central positions, and both have a self-centring lower position, with functions as follows:

"Time & Data": In this up position, the time and a block of data will be printed out when commanded. The time is always printed first. If a print-out is commanded in the last second of a minute, the printer will wait until the time has changed in order to prevent an unreadable print-out of time.

"Time": The time alone will be printed out when the switch is depressed to this position.

When the left-hand PRINT switch is in its central ("Off") position, data will be printed without a preceding time print-out when commanded.

"Auto": In this position, information will be printed out at intervals as selected on the CLOCK CONTROL SELECTOR; the information printed out depends on the position of the left-hand PRINT switch.

"Single": One block of data will be printed out when the switch is de-

pressed to this position; the information printed out depends on the position of the left-hand PRINT switch.

When the 2312 is used in one of the "IEC" modes, the printer is disabled both in the central "Off" position and in the "Single" position, because no manual print command is allowed in these modes.

THUMBWHEEL:

The knurled knob at the bottom centre of the front panel is to release the baseplate to enable the 2312 to be mounted in a rack or portable carrying case. Turn it anticlockwise to release, clockwise to tighten.

LOCK RELEASE:

Two black plastic knobs under the paper outlet which should be moved in the direction of the arrows to swing out the paper-loading frame. See section 3.6.

2.2. REAR PANEL

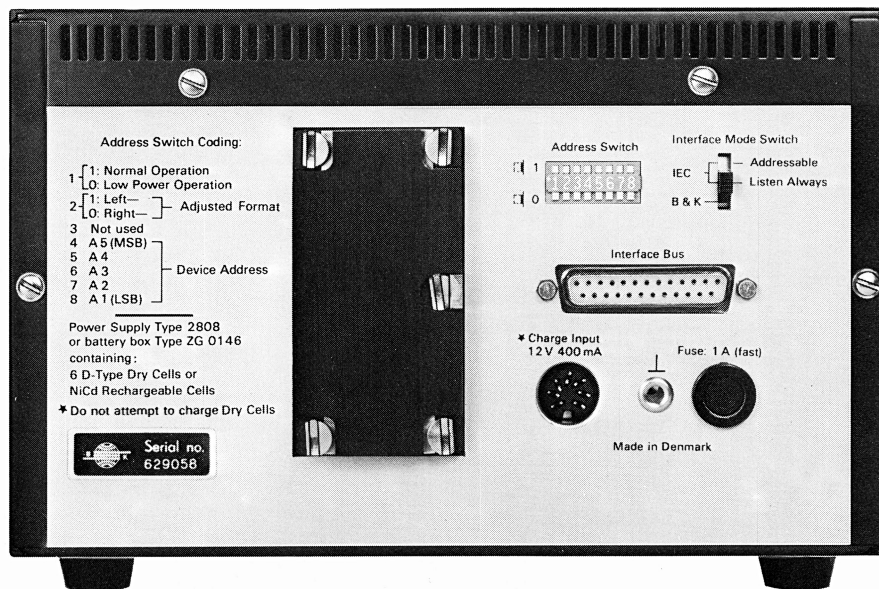

Fig.2.2. Rear Panel of 2312

BATTERY COMPARTMENT:

Compartment for housing the Battery Box ZG 0146 or Power Supply Type 2808. The centre screw on the battery box locks it into the 2312, while the four corner screws retain the lid of the box. See also section 3.2.

ADDRESS SWITCH:

A set of eight small switches with functions as follows:

"1": Selects "Normal Operation" (upper part of knob depressed) or "Low-Power Operation" (lower part of knob depressed). "Low-Power Operation" may always be used, but "Normal Operation" gives better noise immunity in large systems when in an "IEC" mode. See section 4.2.

"2": Selects "Left-Adjusted Format" (upper part of knob depressed) or "Right-Adjusted Format" (lower part of knob depressed).

"3": This switch is not used.

"4" — "8": These switches select the address code for the 2312 in an addressable system, switch "4" setting the most significant bit (MSB) A5, and switch "8" setting the least significant bit (LSB) A1. Depressing the upper part of the knob corresponds to 1, and the lower part corresponds to 0, as marked by the switch. These switches are set to give the 2312 a binary number corresponding to its address in the system. They have no effect if the INTERFACE MODE SWITCH is not set to "IEC — Addressable".

INTERFACE MODE SWITCH:

A three-position slide switch with functions as follows:

"IEC — Addressable": In this mode, the 2312 only acts when a command on the Interface Bus is directed specifically at it using its own address code, as set on the ADDRESS SWITCH. The 2312 interface is in accordance with the IEC proposals for a Standard Interface Bus. The 2312 is thus compatible with most non-B & K instruments using this interface standard, as well as those from B & K. See section 4.4.

"IEC — Listen Always": In this mode, the 2312 is in a permanently addressed state and listens to and acts on each command via the Interface Bus. The 2312 interface is in accordance with the IEC proposals for a Standard Interface Bus. The 2312 is thus compatible with most non-B & K instruments using this interface standard, as well as those from B & K. See section 4.4.

"B & K": In this mode, a modified Interface Bus system is used, which is specifically designed for low-power use in battery-operated systems with some B & K instruments.

INTERFACE BUS SOCKET:

A 25-pin socket for connection to other suitable instruments via the Interface Bus. All control and data signals are sent through this socket, which accepts plug JP 2500 or cable AO 0129, AO 0144, AQ 0138, or AO 0157. The pin connections are given in section 4.1. Selection of cables is discussed in section 3.8.

CHARGING SOCKET:

A seven-pin DIN socket for applying an external voltage to charge the internal (NiCd only) cells of the 2312, and to supply power to the heat resistors which will prevent condensation in damp environments. The pin connections are shown in Fig.2.3. Accepts plug JP 0703 or cable AQ 0035, etc..

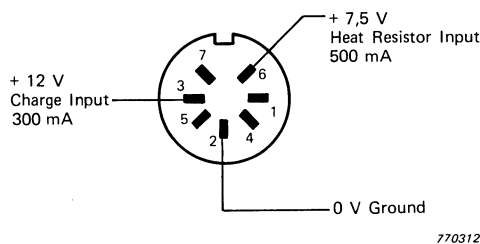

Fig.2.3. Pin connections of CHARGING SOCKET. External view of socket, soldering side of plug, shown

There is a small grounding socket just beside this, which will accept plug JB 0002.

FUSE:

Contains a 1 A fast-blow fuse (20 × 5 mm). To change the fuse, unscrew the black knob, replace the fuse, and screw the knob back again.

3. OPERATION

3.1. MOUNTING

The Alphanumeric Printer Type 2312 is normally delivered in a metal cabinet which has a metal stand for raising the front of the instrument for better viewing.

The 2312 may also be mounted in the Carrying Case KA 2000, which is well suited for outdoor use, as shown in Fig.3.1. The baseplate of the 2312 should be removed, then the feet and the tilt stand are unscrewed. The baseplate is then bolted on to the metal plate inside the Carrying Case KA 2000, and the 2312 is slid back on to its baseplate and secured with the THUMBWHEEL.

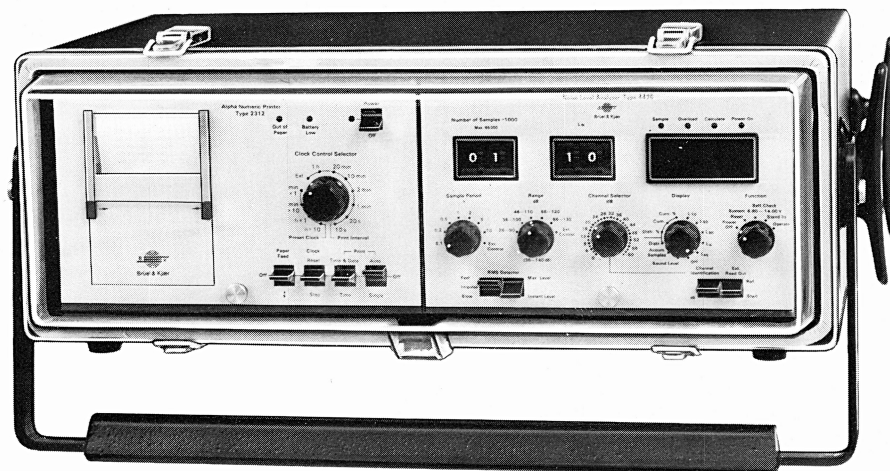

Fig.3.1. Alphanumeric Printer Type 2312 and Noise Level Analyzer Type 4426 in Carrying Case KA 2000

The paper window may be removed by pushing the plexiglass plate upwards. During operation, the paper will fold inside the lid of the Carrying Case. At least 2 m (or 400 lines) of print-out can be collected in this way.

3.2. POWER SUPPLY

There are two methods of supplying power to the 2312. Although it is primarily a small lightweight portable instrument which is driven by its own internal batteries, it may also be powered from a mains power supply. The choice of external power supply depends on whether it only has to be capable of recharging the internal cells, or whether it also has to power other instruments in the measurement chain at the same time. The various possibilities are outlined in the following sections.

3.2.1. Plug-in Power Pack

Removing the Power Pack from the Instrument

1. Using a screwdriver or a coin, turn the screw-headed supply lock through 180° (see Fig.3.2).

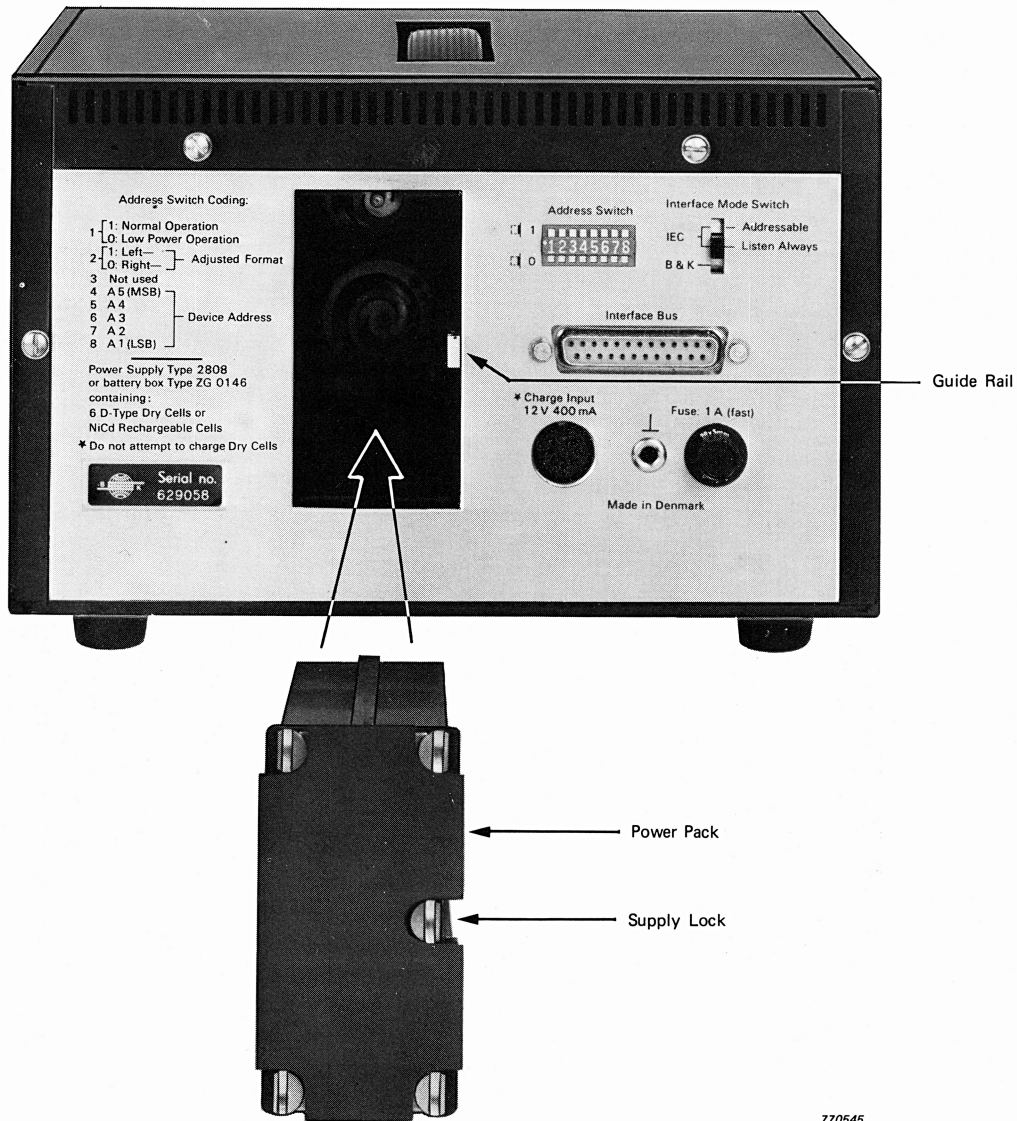

Fig.3.2. Removing Power Pack from 2312

2. Slide the Battery Box ZG 0146 out of the 2312.

Fitting Cells into the Battery Box

1. Using a screwdriver or a coin, turn the four fastening screw heads through 180° and remove the lid, as shown in Fig.3.3.
2. If old cells need to be removed, gradually tilt the Battery Box until they slide out of the open end.

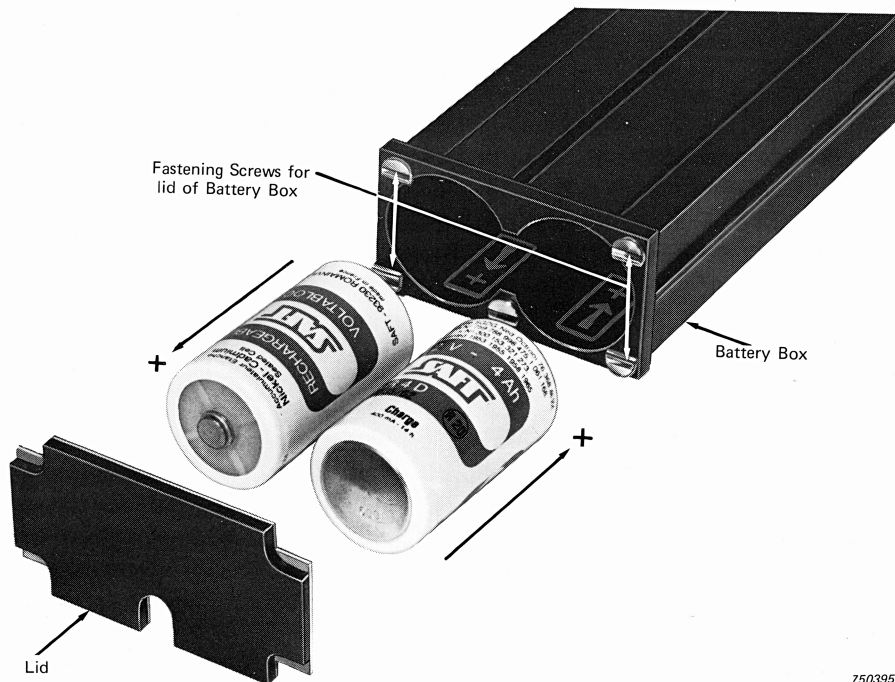

Fig.3.3. Fitting cells into Battery Box

3. Load six new cells (QB 0004 or QB 0008) into the Battery Box as shown in Fig.3.3. Care should be taken to ensure that the positive pole of each cell (the stud on its casing) faces the direction indicated in each of the two compartments of the box.

WARNING: There is a possibility of explosion if recharging is attempted on cells that have been fitted with their polarities reversed, or on non-chargeable cells.

4. Replace the lid and lock it onto the Battery Box by turning the four fastening screw heads through 180°.

Installation of the Power Pack

1. Place the Power Pack in the position shown in Fig.3.2 so that the end of the channel in the side of the Power Pack is located against the guide rail in the 2312's battery compartment.
2. Push the Power Pack into the battery compartment so that when almost completely inserted it comes to rest against the two spring-loaded pole contacts in the 2312.
3. Using a firm but not excessive pressure, push the Power Pack against the pole contacts, and turn its screw-headed supply lock through 180° so that it is located in the slot at the outer end of the guide rail.
4. Switch on the instrument power; the POWER ON INDICATOR should light or flash. If it does not, or if the BATTERY LOW INDICATOR lights, replace or recharge the cells as necessary. If no lights come on, check the fuse. Switch off the instrument power after the battery check.

Replacement of Cells

The alkaline cells (QB 0004), as supplied with the instrument, need to be replaced when the BATTERY LOW INDICATOR flashes and the print-out is inhibited. Nickel-Cadmium cells need to be recharged under the same conditions. The type recommended are SAFT VOLTA BLOCK Type VR 4D which have a voltage and charge rating of 1,2 V and 4 ampère hours respectively. (Other rechargeable cells with similar specifications may also be used.) SAFT, the cell manufacturers, specify that with normal use the cells have a minimum of 300 charge cycles before replacement is necessary. The need for replacement is indicated by the cells failing to recharge fully when left on charge for 19 hours or more.

3.2.2. Plug-in Power Supply Type 2808

The Power Supply Type 2808 (see Fig.3.4) is a double-insulated supply which may be used to power the 2312 from a mains supply of between 100V and 240V AC (50 to 400Hz). It is exactly the same size and shape as the Battery Box ZG 0146, and is inserted into the Battery Compartment in an identical manner. It may also be used to supply power to the heat resistors (see section 3.4). In addition, the 2808 has sufficient power to drive other portable instruments and/or to recharge their cells at the same time using cable AQ 0035. See the 2808 Instruction Manual for its maximum current and voltage ratings, as well as the Instruction Manuals for other instruments being powered and/or charged.



Fig.3.4. Power Supply Type 2808

If the 2312 is fitted with rechargeable (NiCd) cells, the 2808 may also be used to recharge them, either internally or externally, as described below.

Voltage and Fuse Selection for the 2808

Before using the 2808, it is important to ensure that the current rating of its internal mains fuse and its VOLTAGE SELECTOR setting are appropriate for the voltage of the mains power supply with which it is to be used. Full details of this, and other relevant information, are given in the 2808 Instruction Manual.

Powering the 2312 from the 2808

The 2808 CHARGE SWITCH should be set to "Off" (unless another instrument or Power Pack is to be charged simultaneously, or the heat resistors are to be powered), and the 2808 inserted into the 2312 Battery Compartment in place of the Power Pack. Installation and power supply check are identical to the descriptions given in section 3.2.1. With the 2808 connected to the mains power supply, the 2312 will be powered. The 2808 may also simultaneously power the heat resistors if required (see section 3.4).

Recharging the NiCd Cells in the 2312 from the 2808

The rechargeable (NiCd) cells in the 2312 may be recharged as follows. With the 2808 outside the 2312, connect the 2808 OUTPUT socket to the 2312 CHARGING SOCKET via cable AQ 0035, and set the 2808 CHARGE SWITCH to "Charge". (In fact only pins 2 and 3 on the 2808 socket need to be connected to pins 2 and 3 respectively on the 2312 socket; although the cable AQ 0035 connects all seven pins of each socket pin 1 to pin 1, pin 2 to pin 2, etc., there is no need to disconnect any.) Normally, the 2312 will be charged whilst it is switched off, but it can be operated during recharging, if required, provided that the BATTERY LOW INDICATOR is not flashing, as will be the case after a period of charging, as long as the average current drawn by the 2312 does not exceed 300 mA (corresponding to a pause:print ratio greater than 1). For a totally discharged Power Pack, the recharging time is approximately 19 hours at a nominal charge rate of 300 mA.

External Charging of Separate Power Packs from the 2808

It is often useful to have a spare Power Pack which can be recharged, in the laboratory for example, whilst the other is powering the instrument. Thus the Power Pack being recharged is outside the 2312, and a slightly different procedure is necessary. A Charging Adaptor AQ 0157 has to be attached to the Battery Box ZG 0146 at the opposite end from its lid. Its two locating arms are slid down the grooves at the top and bottom of the Battery Box, and the Charging Adaptor is held in position by a spring-loaded retaining pin on each of the arms. A further locating pin, which fits into the end of the Battery Box, ensures that the Charging Adaptor is fitted the correct way up to ensure the correct polarity. The Charging Adaptor about to be located on the Battery Box is shown in Fig.3.5. The power supply contacts are also spring loaded, and this holds the retaining pins in position. A seven-pin DIN plug on the end of the lead from the Charging Adaptor is directly connected to the 2808 OUTPUT socket, and the 2808 is set to "Charge".

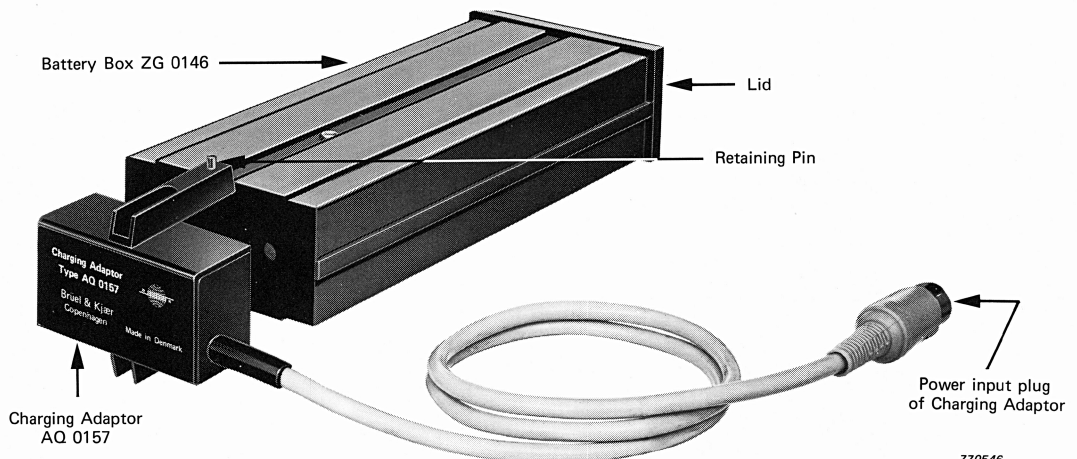

Fig.3.5. Charging Adaptor AQ 0157 and Battery Box ZG 0146

When charging is completed, the Charging Adaptor is released by pressing it towards the Battery Box, thus disengaging the spring-loaded retaining pins. The Charging Adaptor may then simply be slid off the Battery Box.

3.2.3. Battery Charger ZG 0113

The Battery Charger ZG 0113 (see Fig.3.6) is a double-insulated charger which may be used to recharge the NiCd cells of the plug-in Power Pack whilst it is installed in the 2312. It can provide up to 400 mA at 12 V DC, and incorporates a thermal overload cut-out which operates at 80°C. The power cable of the ZG 0113 is merely plugged into the mains supply, and its DIN plug is connected to the 2312 CHARGING SOCKET. The charging time is approximately 19 hours. The colour coding of the power cable for the different mains voltages is as follows:

Brown:	200 — 240 V AC
Black:	100 — 130 V AC
Blue:	Neutral

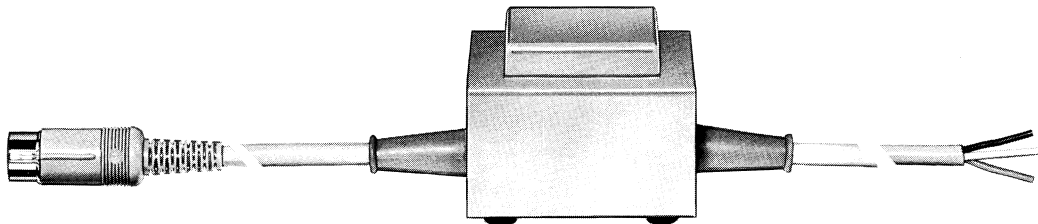

Fig.3.6. Battery Charger ZG 0113

3.3. GROUNDING THE 2312

When the 2312 is delivered, the signal ground is internally connected to the chassis via a wire strap near the input connector. In large instrument systems where special precautions should be taken to prevent noise interference from ground leads, it is often desired to have a connection between signal ground and chassis ground at only one point in the system, usually at the system controller. In this case the strap should be disconnected as follows:

1. Unscrew the top plate of the 2312 and slide it off rearwards.
2. Unplug the flat-cable connector on the printed-circuit board on the backplate (see Fig.3.7).
3. Unsolder the wire strap (see Fig.3.7), and move it away from the terminal.
4. Reconnect the flat-cable connector to the printed-circuit board.
5. Replace and fasten the top plate.

The chassis of the 2312 is now still connected to earth via the shield in the interface cable, while the electronics ground is connected to signal ground in the cable. To reconnect the signal ground to the chassis, simply solder the wire strap back again.

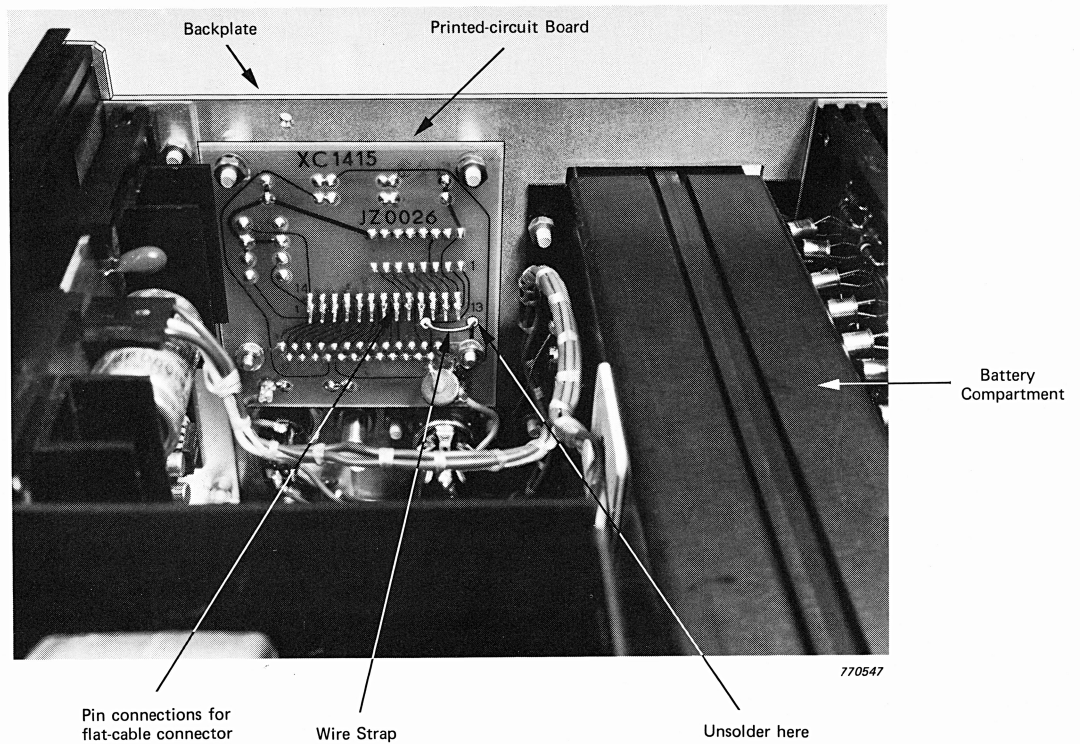

Fig.3.7. Position of wire grounding strap

3.4. HEAT RESISTORS

For use in a damp environment (tropical climate, for example), the 2312 has been equipped with heat resistors to prevent condensation forming, because the normal internal heat dissipation is extremely low. The resistors are connected to the CHARGING SOCKET, pin 6, as shown in Fig.2.3. To power these resistors, a voltage of between 7 and 10 V DC should be applied to this pin, the current consumption being approximately 500 mA.

If the Power Supply Type 2808 is installed inside the Battery Compartment to power the 2312 from the mains, a special cable AQ 0213 (Fig.3.8) is available to connect the 2808 OUTPUT socket to the CHARGING SOCKET of the 2312. The cable is symmetrical and may be used either way round. There is no ground connection to prevent ground loops, and this means that it can only be used when the 2808 is fitted inside the 2312. The 2808 should be set to "Charge" since the "charging" current will compensate in part for the current drawn from the main power supply. The heat resistors are also powered when the 2312 is switched off.

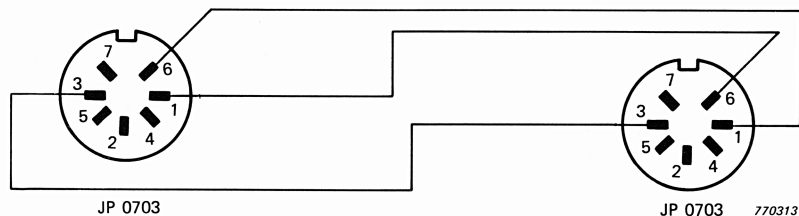

Fig.3.8. Cable AQ 0213 for powering the heat resistors of the 2312. External view of sockets, soldering side of plugs, shown

3.5. PREPARATION FOR USE/MAINTENANCE

3.5.1. Printer Head

During operation, chemicals from the heat-sensitive paper may build up on the thermal printer head, and this will cause the printing to gradually become weaker. The printer head should be carefully cleaned with alcohol and a soft cloth after each 4 rolls of paper. **The printer head surface is covered with quartz and is thus insensitive to most chemicals, but care must be taken to avoid scratching it with hard instruments.**

3.5.2. Paper-feed Rubber Roller

The paper-feed rubber roller can pick up dust, and for this reason it should be cleaned occasionally, or whenever it gets dusty. It is made from silicone rubber which is insensitive to most solvents. It should be carefully wiped using a clean cloth and, for example, alcohol. Remove the paper, depress the PAPER FEED switch, and slide the cloth slowly across the roller. **The rubber surface will be damaged if the roller is compressed by any hard materials.**

3.6. PAPER LOADING AND STORAGE

3.6.1. Loading the Paper

Heat-sensitive paper, 60 mm wide, is used for the Alphanumeric Printer Type 2312. The procedure for loading the paper is as follows:

1. Squeeze the two black plastic LOCK RELEASE knobs on the front panel of the 2312 towards each other (in the direction of the arrows), and swing the paper-loading frame outwards as shown in Fig.3.9.

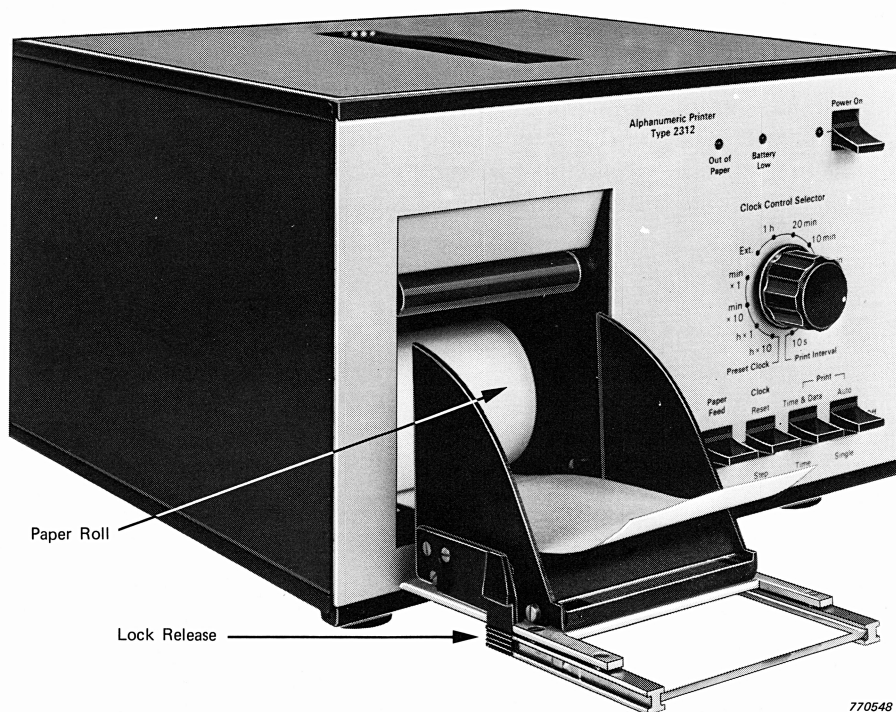

Fig.3.9. Position of paper-loading frame for paper insertion

2. Remove the remainder of the old roll of paper and the reel from the paper-holding magazine.
3. Insert the new roll of paper into the magazine, so that the paper is fed out from the underside of the roll, as shown in Fig.3.9.
4. Pull the end of the paper until it lies just beyond the transparent front cover of the paper-loading frame.
5. Holding the end of the paper in that position, swing the frame back into position until a "click" is heard. The paper should now just protrude out of the opening.

3.6.2. Paper Storage

Unused paper storage

The rolls of heat-sensitive paper should be stored in a dry place, and must not be exposed to temperatures above 65°C (149°F). Storage near solvents such as acetone and alcohol should also be avoided, since vapours from these will cause discoloration of the paper.

Print-out storage

For long-term storage of print-outs, water-soluble glues should be used for mounting, and the print-outs should be wrapped in paper. Excessive exposure to sunlight or contact with plastics will cause the printing to fade.

3.7. SETTING THE CLOCK

3.7.1. Initial Setting

Before starting to print out data, it is often convenient to preset the 2312's internal clock to the correct time of day. The clock will then continue to keep time very accurately until the 2312 is switched off, and will print out the day (from "0" to "99"), the hour, and the minute whenever requested to do so, for example, with each block of data. The procedure for setting the clock to a time of, for example, 16:23 is as follows:

1. Turn the 2312 POWER ON switch to its upper ("On") position.
2. Set the CLOCK CONTROL SELECTOR to one of the "Preset Clock" positions, for example "min × 1".
3. To obtain an exact setting of the minutes, watch the reference clock (for example, a wrist watch), and when the second hand passes twelve, or when the seconds of a digital watch indicate zero, press the CLOCK switch up to its "Reset" position, and immediately release it.

The seconds, although not displayed in the print-out, have now been synchronized to the real time, and the digits for hours and minutes should now be set within the first minute.

4. To preset the tens of hours (in this case to "1" for a time of 16:23), set the CLOCK CONTROL SELECTOR to "h × 10", and depress the CLOCK switch **once** momentarily to its "Step" position, and then release it.

5. To preset the units of hours (in this case to "6" for a time of 16:23), set the CLOCK CONTROL SELECTOR to "h × 1", and depress the CLOCK switch **6 times** to its "Step" position, and then release it.
6. To preset the tens of minutes (in this case to "2" for a time of 16:23), set the CLOCK CONTROL SELECTOR to "min × 10", and depress the CLOCK switch **twice** to its "Step" position, and then release it.
7. To preset the units of minutes (in this case to "3" for a time of 16:23), set the CLOCK CONTROL SELECTOR to "min × 1", and depress the CLOCK switch **3 times** to its "Step" position, and then release it.
8. Immediately turn the CLOCK CONTROL SELECTOR to one of its "Print Interval" positions, or the minutes will not advance the clock.

Note: The order of setting the hours and minutes is not important; steps 4—7 can be made in any order.

3.7.2. Resetting the clock

The time setting can be simply checked by depressing the left-hand PRINT switch to "Time", and a sample print-out of time will be effected. If any one of the digits has been incorrectly set, it is not necessary to reset the time to zero and repeat the whole procedure; the incorrect digit can be reset individually. For example, if the time should have been 16:23, but the "Step" was depressed 4 times by mistake in the "min × 1" position, so that "16:24" was preset, it is corrected as follows:

1. Turn the CLOCK CONTROL SELECTOR to the appropriate digit (in this case "min × 1").
2. Depress the CLOCK switch to "Step" the appropriate number of times (in this case 9) to go from "4" past zero to "3". (There is no "carry-over" facility in the "Preset Clock" and "Step" mode, so the tens of minutes will not be affected.)
3. Immediately turn the CLOCK CONTROL SELECTOR to one of its "Print Interval" positions.

The time will now have been correctly set to "16:23", and the clock will now accurately keep time.

3.7.3. Setting the Day

Since there is no "carry-over" facility in the "Step" mode, it is not possible to set the day in the normal manner. For example, stepping 1 minute onto a time of "23:59" will give a time of "23:50". It is, however, possible to set up a time of "23:59" on day "00" (giving a setting of "00:23:59"), set the CLOCK CONTROL SELECTOR to one of its "Print Interval" positions, and wait until the time goes to "01:00:00". Then the time can be reset to "01:23:59", and the procedure repeated. This is rather a time-consuming process if the day has to be set beyond one or two.

3.8. SELECTION OF CABLES

The available cables to be connected to the INTERFACE BUS SOCKET are as follows:

The first three cables are for interconnecting B & K instruments.

- AO 0129: This is a standard 25-lead round cable with twisted pairs, giving good transmission characteristics. It has male D-connectors with slide locks at each end. The cable length is 1,5 m.
- AO 0144: This is a shorter 25-lead round cable with male D-connectors and slide locks. The cable length is 0,6 m.
- AQ 0138: This is a short 25-lead flat cable, for use where mechanical ruggedness is not required. The cable length is 0,4 m.

This cable is for connecting B & K instruments to IEEE-standard instruments.

- AO 0157: This is a special cable for connecting B & K instruments with an IEC interface to other instruments with a standard IEEE connector. The cable length is 1,5 m.

An adaptor is also available:

- JP 2550: This adaptor is for connecting the female D-connector at the rear of B & K instruments to a male D-connector. This is for use with cables which have female D-connectors.

3.9. USE OF THE ALPHANUMERIC PRINTER TYPE 2312

The way in which the 2312 is used is basically similar regardless of the instrumentation to which it is connected. It is the operation of the other instrumentation (for example, the Noise Level Analyzer Type 4426) which sometimes needs special attention, and further details will be found in the Instruction Manuals for the appropriate instruments. The following instructions should be used as a general guide to the use of the 2312 in conjunction with other compatible instruments, which include the Digital Frequency Analyzer Type 2131 (when fitted with an IEC interface), Noise Level Analyzer Type 4426, and the Strain Indicator Type 1526/Multipoint Selector and Control Type 1544 combination. Details of the interfacing may be found in Chapter 4.

1. Connect the 2312 INTERFACE BUS SOCKET to the relevant digital output socket of the instrument(s) from which data is to be obtained using cable AO 0129 or other suitable cable. Ensure the cable is correctly fitted.
2. Set the INTERFACE MODE SWITCH as required (see section 2.2).
3. Select "Normal Operation" or "Low-Power Operation" with switch "1" on the ADDRESS SWITCH. "Low-Power Operation" is preferred when the 2312 is battery operated. The specified battery life on standby can only be expected when instruments connected to the interface bus are equipped with the B & K "low-power" interface. If IEC interface instruments are connected to the bus, battery life on standby will be reduced to 1/3 of the rated value (see sections 2.2 and 4.2).
4. Select the print-out format and the instrument address code (if necessary) using the ADDRESS SWITCH (see sections 2.2 and 4.1).
5. Set the PRINT "Auto" switch to its central "Off" position.
6. Install the required power supply and a roll of paper (see sections 3.2 and 3.6), and switch on the instrument. The POWER ON INDICATOR should light or flash.

7. Set the required time with the CLOCK CONTROL SELECTOR and CLOCK switch, depress the left-hand PRINT switch to "Time" for a sample print-out and then select the "Print Interval" as required (see section 2.1).
8. Select "Time & Data" or "Data", as required, with the left-hand PRINT switch.
9. If the INTERFACE MODE SWITCH is set to "B & K", go to step 10; if it is set to one of the "IEC" modes, go to step 11.
10. In the "B & K" mode, a data transmission/print-out sequence may be started in any of three different ways:
 - a) Depress the PRINT switch to "Single" and release it.
 - b) Turn the CLOCK CONTROL SELECTOR to "Ext." and set the PRINT switch up to "Auto". A print-out can then be controlled from the instrument which is sending the data.
 - c) Select the required "Print Interval" with the CLOCK CONTROL SELECTOR. With the PRINT switch set to "Auto", a print-out is started at the required intervals, timed by the built-in clock.

In the wait state until a new print-out is started, signal lines RFD and DAC (see section 4.1) will both remain passive high.

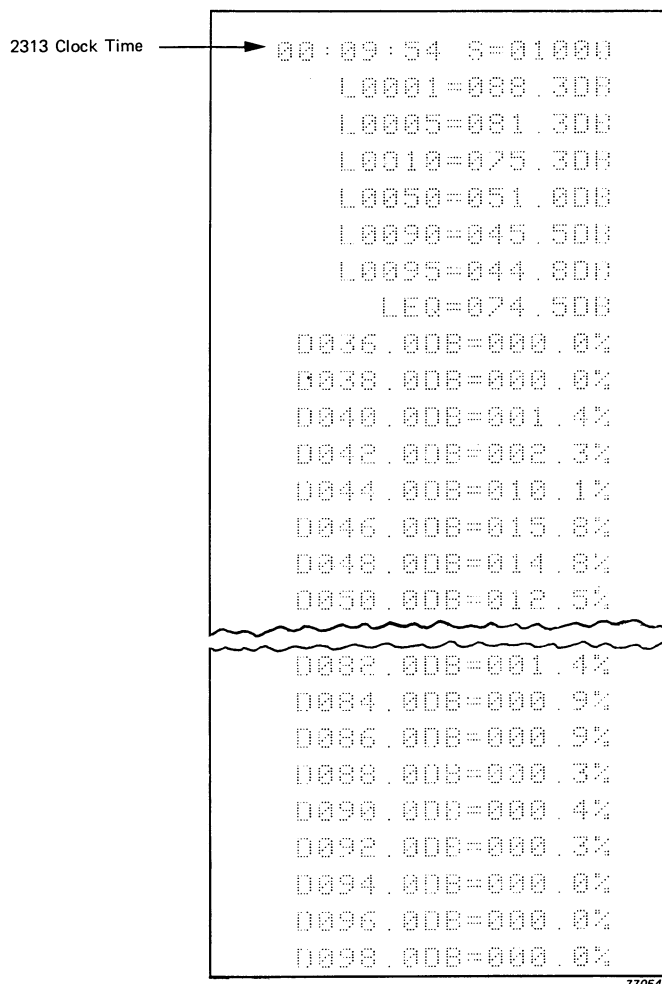

Fig.3.10. Example of 2312 print-out from 4426

If the PRINT switch is set to "Off" during a print-out, that particular print-out will be continued until the END command is received, but a new one cannot be started without resetting the switch.

11. a) In the "IEC — Listen Always" mode, the 2312 is always addressed when the PRINT switch is set to "Auto". The "Print Interval" is selected with the CLOCK CONTROL SELECTOR.
- b) In the "IEC — Addressable" mode, the 2312 must have its address code selected with switches "4" — "8" of the ADDRESS SWITCH (see sections 2.2 and 4.1). When the controlling instrument in the chain sends the appropriate address code, the 2312 is activated and receives and prints the information directed to it. The un-addressing takes place using the code for "?" and the ATN = Low. The other controls should be set as for "IEC — Listen Always".

When the 2312 enters a wait state in one of the "IEC" modes (using the interval timers), the handshake is inhibited since RFD is active low (holds the line down) and DAC is passive high.

Unlike the "B & K" mode, the print-out will be inhibited immediately when the PRINT switch is shifted from "Auto" to "Off" or "Single" (no manual start).

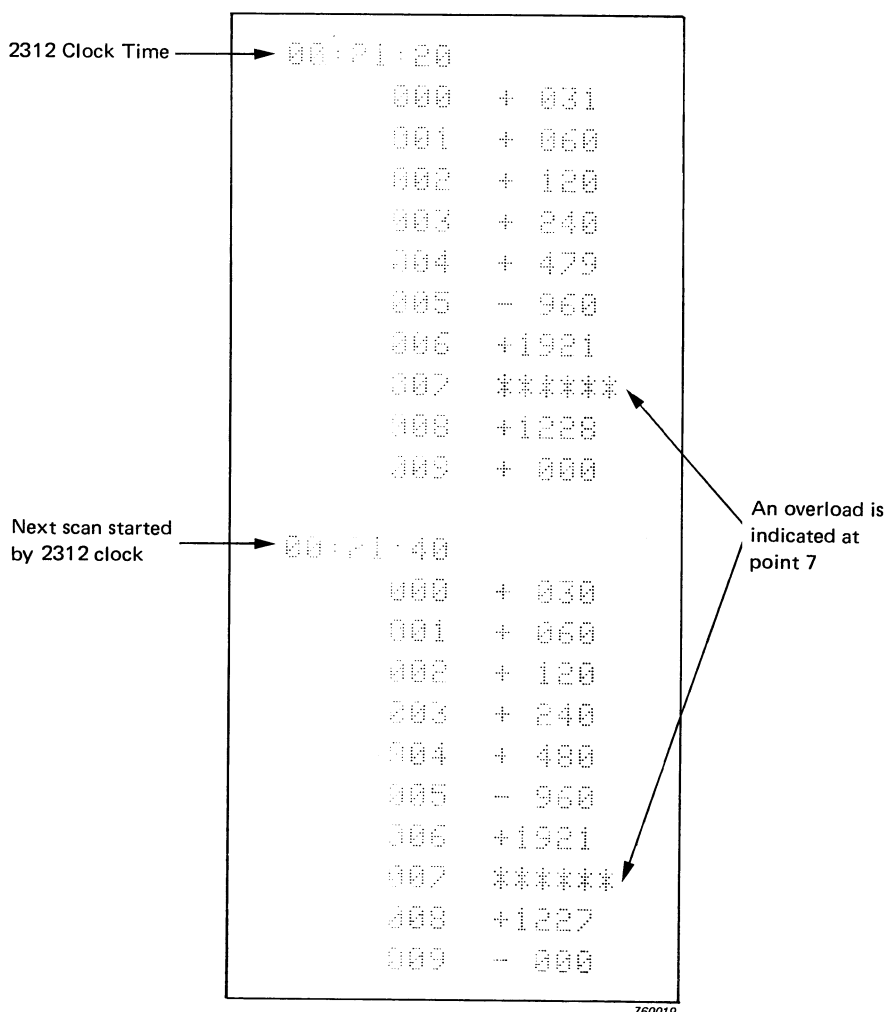

Fig.3.11. Example of 2312 print-out from 1526/1544 combination

Some examples of print-out formats are given in Figs.3.10 and 3.11. The actual print-outs are a cobalt blue colour. Fig.3.10 gives an example of a print-out from the 4426 showing first the time, which is always left-justified, and the accumulated number of samples (S). Following this are various L_N values, and L_{eq} , and then a list of distribution (D) functions as percentages. Note that the zeroes are denoted by \emptyset . Apart from the time, everything in this example is right-justified. See also the 4426 Instruction Manual.

Fig.3.11 gives an example of a strain print-out from the 1526/1544 combination. The time has been printed out with each file (block) of data, which consists of the strain at various measuring points (numbered 0 to 9). Again, time is left-justified and the rest of the data is right-justified.

4. INTERFACING THE 2312 TO OTHER INSTRUMENTS

4.1. PRINCIPLE OF THE PROPOSED IEC INTERFACE

The interface-bus structure defined by the proposed IEC Interface Standard allows the connection of up to 16 instruments to the same cable. The instruments are connected by 16 signal lines, subdivided into 3 groups, as shown in Fig.4.1, consisting of 8 data lines, 3 handshake lines, and 5 general control lines.

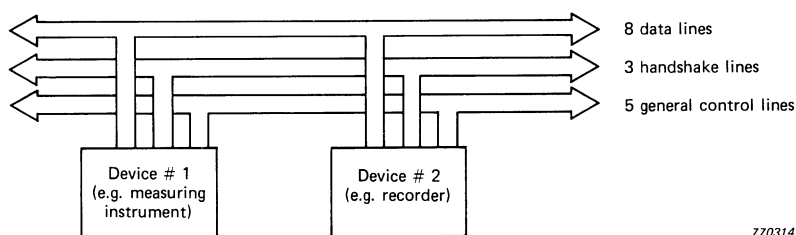

Fig.4.1. The signal lines of the proposed IEC interface

The pin connections of the INTERFACE BUS SOCKET on the rear panel of the 2312 are given in Fig.4.2 and Table 4.1. For selection of the correct cable, see section 3.8.

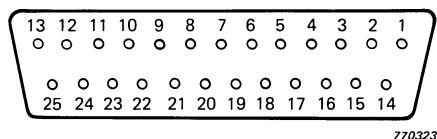

Fig.4.2. Pin numbers of the INTERFACE BUS SOCKET

Using positive logic representation, all signals except RFD and DAC are inverted on the bus.

Data are transmitted in byte-serial bit-parallel form on the data lines $\overline{D1}$ to $\overline{D8}$, i.e. each data byte is transmitted consecutively as 8 bits in parallel. The transmission code is 7-bit ASCII (see Table 4.2) with $\overline{D8}$ left for check-bit purposes. The 2312 does not sense this line.

Pin No.	Function	Description
1	$\overline{D} 1$	Data line
2	$\overline{D} 2$	Data line
3	$\overline{D} 3$	Data line
4	$\overline{D} 4$	Data line
5	\overline{REN}	Remote Enable
6	\overline{EOI}	End or Identify
7	\overline{DAV}	Data Valid
8	RFD	Ready for Data
9	DAC	Data Accepted
10	\overline{IFC}	Interface Clear
11	\overline{SRQ}	Service Request
12	\overline{ATN}	Attention
13	Shield	—
14	$\overline{D} 5$	Data line
15	$\overline{D} 6$	Data line
16	$\overline{D} 7$	Data line
17	$\overline{D} 8$	Data line
18	Ground	(Twisted pair with pin 6)
19	Ground	(Twisted pair with pin 7)
20	Ground	(Twisted pair with pin 8)
21	Ground	(Twisted pair with pin 9)
22	Ground	(Twisted pair with pin 10)
23	Ground	(Twisted pair with pin 11)
24	Ground	(Twisted pair with pin 12)
25	Ground	—

770401

Table 4.1. Pin connections of the INTERFACE BUS SOCKET

Handshaking, or data transfer control, is performed by the following signal control lines:

\overline{DAV} , Data Valid, sent by the transmitter
 RFD, Ready for Data } sent by the receiver
 DAC, Data Accepted }

In connection with the open-collector output drivers to the bus, this transfer control structure allows only one transmitter to send data while several receivers can accept the data simultaneously. The timing sequence is shown in Fig.4.3.

The three-wire handshake is asynchronous, and the transmission speed is determined by the slowest participator in the transfer. The only timing requirement is a minimum $2\mu\text{s}$ delay from the moment data is changed until \overline{DAV} goes low.

				b ₇	0	0	0	0	1	1	1	1
				b ₆	0	0	1	1	0	0	1	1
				b ₅	0	1	0	1	0	1	0	1
				Column	0	1	2	3	4	5	6	7
b ₄	b ₃	b ₂	b ₁	Row								
0	0	0	0	0	NUL	TC ₇ (DLE)	SP	0	@	P	'	p
0	0	0	1	1	TC ₁ (SOH)	DC ₁	!	1	A	Q	a	q
0	0	1	0	2	TC ₂ (STX)	DC ₂	"	2	B	R	b	r
0	0	1	1	3	TC ₃ (FTX)	DC ₃	#	3	C	S	c	s
0	1	0	0	4	TC ₄ (EOT)	DC ₄	\$	4	D	T	d	t
0	1	0	1	5	TC ₅ (ENQ)	TC ₈ (NAK)	%	5	E	U	e	u
0	1	1	0	6	TC ₆ (ACK)	TC ₉ (SYN)	&	6	F	V	f	v
0	1	1	1	7	BEL	TC ₁₀ (ETB)	'	7	G	W	g	w
1	0	0	0	8	FE ₀ (BS)	CAN	(8	H	X	h	x
1	0	0	1	9	FE ₁ (HT)	EM)	9	I	Y	i	y
1	0	1	0	10	FE ₂ LF	SUB	*	:	J	Z	j	z
1	0	1	1	11	FE ₃ (VT)	ESC	+	;	K	[k	{
1	1	0	0	12	FE ₄ (FF)	IS ₄ (FS)	,	<	L	\	l	
1	1	0	1	13	FE ₅ CR	IS ₃ (GS)	-	=	M]	m	}
1	1	1	0	14	SO	IS ₂ (RS)	.	>	N	^	n	_
1	1	1	1	15	SI	IS ₁ (US)	/	?	0	-	o	DEL

770400

Table 4.2. 7-bit ASCII transmission codes

Control lines are used for the transmission of uniline remote messages, as follows:

$\overline{\text{ATN}}$,	Attention	} sent by the controller
$\overline{\text{REN}}$,	Remote Enable	
$\overline{\text{IFC}}$,	Interface Clear	
$\overline{\text{SRQ}}$,	Service Request,	sent to the controller
$\overline{\text{EOI}}$,	End or Identify,	sent by any device

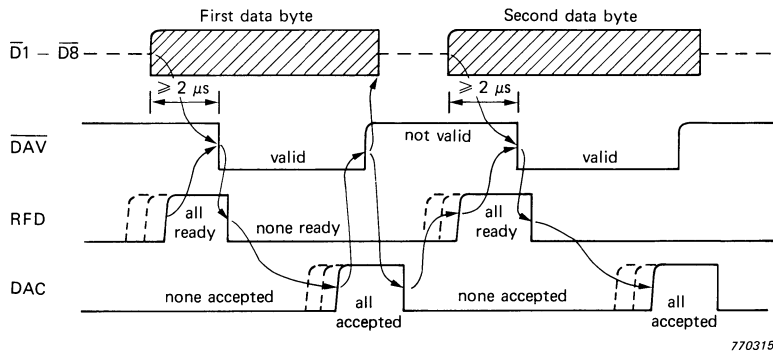

Fig.4.3. Handshake timing sequence with multiple listeners

\overline{ATN} is low while the controller is sending interface commands, e.g. address commands, to other devices.

\overline{REN} is low when selected devices on the interface bus must act according to a program transmitted via the bus, instead of obeying the selected front-panel settings.

\overline{IFC} transmitted low will reset any device connected to the bus to a predefined passive state.

\overline{SRQ} is an interrupt message which, when sent to the controller, indicates that one of the devices on the bus requires special service. The 2312 is not able to send this message.

\overline{EOI} has a double function. When \overline{EOI} and \overline{ATN} are sent low by the controller, the message is \overline{IDY} , Identify. \overline{IDY} is used when the controller demands identification from the device having sent the \overline{SRQ} message. The 2312 is not able to respond to an \overline{IDY} message. When \overline{EOI} is low and \overline{ATN} is high, the message sent is \overline{END} . \overline{END} is used to indicate the last byte in a transmission. The 2312 will respond to this message as described in sections 4.2 and 4.3.

Addressing. Each device connected to the interface bus has its own individual address, consisting of a 5-bit binary code selected by a switch array, usually placed on the rear panel of the instrument. The controller transmits address messages as data while \overline{ATN} is low. The codes used are shown in Table 4.3.

0 1 X X X X X	Listener address
0 1 1 1 1 1 1	UNLISTEN
1 0 X X X X X	Talker address
1 0 1 1 1 1 1	UNTALK

X X X X X : 5 bit individual code

770316

Table 4.3. IEC address codes

When in the addressable mode, each device can only transmit or receive data when it has been specifically addressed by the controller, and after the UNTALK or UNLISTEN

command it will only react to interface commands from the controller. Some devices may be set to the "Talk Always" or "Listen Always" mode, used when addressing from a controller is not required.

4.2. THE B & K LOW-POWER INTERFACE

The special Brüel & Kjær interface for use with battery-powered equipment is basically similar to the proposed IEC interface. The low-power interface works in a semi-addressable manner, since the assignment of the talker and listener in a system is controlled manually, and a data transfer can be initiated by any device (either manually or automatically) during the \overline{STA} (Start) command sent on the \overline{ATN} line. The command \overline{END} ($\equiv \overline{EOI} \wedge \overline{ATN}$) must terminate a transfer to return the devices to their wait states.

A 6,2 k Ω "pull-down" resistor required in the proposed IEC interface for the termination of all signal lines has been omitted to reduce the current drain from the interface during standby. Noise immunity is hereby decreased in larger systems, but this will not affect smaller systems composed of battery-powered equipment. In the 2312, the "pull-down" resistors are removed when the printer is set to "Low-Power Operation" with switch "1" on the ADDRESS SWITCH.

The remote function is not used in the low-power equipment, and therefore the \overline{REN} command will disable the interface as long as \overline{REN} is low.

4.3. CODES AND FORMATS FOR THE 2312

With reference to Table 4.2 (section 4.1), columns 0 and 1 contain the control codes of which only \overline{CR} (Carriage Return) and \overline{LF} (Line Feed) are recognized by the 2312, while the rest of the codes are "handshaken" but their functions are ignored by the interface.

Columns 2, 3, 4, and 5 contain the 64 characters which will be printed by the 2312, whilst columns 6 and 7 are lower-case (small) characters which will be converted to upper case (capital) and printed by the 2312 like the characters in columns 4 and 5.

The print-out format is determined from the transmitter by sending the appropriate number of characters and blanks beginning from the left-hand side and with a maximum of 16 characters per line. Each line is terminated by one of the following:

1. Line Feed (\overline{LF})
2. Carriage Return + Line Feed ($\overline{CR} + \overline{LF}$)
3. \overline{END} ($\overline{EOI} \wedge \overline{ATN}$) with the last byte
4. \overline{LF} and \overline{END} simultaneously

Note that \overline{CR} should precede \overline{LF} , otherwise \overline{CR} must wait for transmission until the beginning of the next line. Carriage Return itself has no effect on the printer.

When lines are terminated as 1 or 2, the printer is ready for new data immediately after the print-out. When lines are terminated as 3 or 4, the printer will enter a wait state, and stay there until a selected time/print interval runs out or until it is otherwise reactivated.

4.4. COMPATIBILITY

It is important to note that the proposed IEC Interface Bus Standard only specifies the

transfer of data between different devices, and that it does not concern itself with the interpretation of these data. Thus full compatibility between instruments from different manufacturers cannot be guaranteed.